

Syphon Model SY1

Features

- Similar to DIN 16 282/ Industrial standards
- Male thread end for process side and weld end on process side
- Protect pressure measuring instrument from direct heating.
- U-Type for horizontal tapping
- Q-Type for vertical tapping

Applications

To protect pressure measuring instrument excessive heating
For liquids, gas or steam
Mounted on Shut-off valve or stop cock
Reduce the effect of rapid pressure surges

Permissible Pressure and Temperature Rating

100	kg/cm ²	@	100°C	(212°F)
95	kg/cm ²	@	150°C	(302°F)
85	kg/cm ²	@	250°C	(482°F)
80	kg/cm ²	@	300°C	(572°F)
70	kg/cm ²	@	350°C	(662°F)
63	kg/cm ²	@	400°C	(752°F)

2
YEARS
WARRANTY



General dimensions in mm

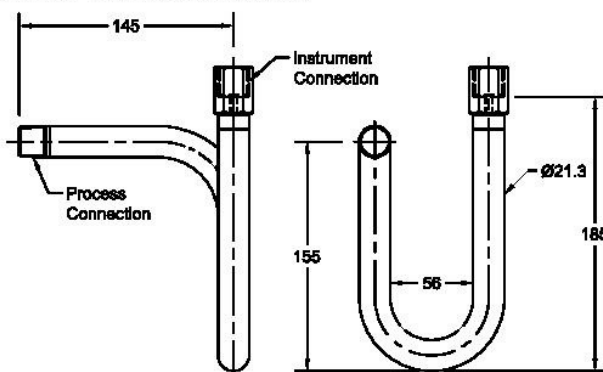

U-type

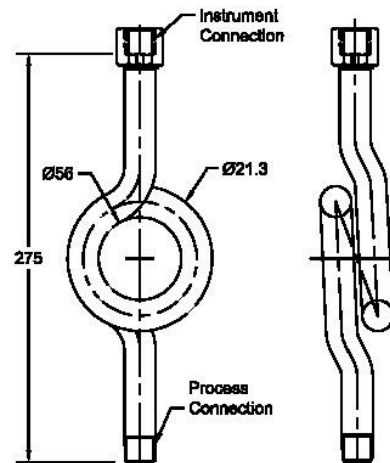

Q-type

Order information

Type	Connection	Form ¹⁾	System material	Design/schedule	Options
SY1	(04) 1/2" NPT (15) 1/2" BSP (16) M20x1.5 Others on request	(M/F) Male X female (M/M) Male X Male (F/F) Female X female (F/B) Female X Blank for weld (M/B) Male X Blank for weld	(C) SS 304 (S) SS 316 (L) SS 316L (CS) Carbon steel ASTM A106	(U40) U type SCH 40 (Q40) Q type SCH 40 (Q80) Q type SCH 80	(NH) Tagging Wired (CDIBR) IBR Certified (CD3) Material certificate for wetted parts

1) For Form, First character indicates Process connection and Second character indicates Instrument connection

How to order

Type	Connection	Form	System material	Design / schedule	Options
SY1	04	M/F	S	U40	CDIBR